

(12) INTERNATIONAL APPLICATION PUBLISHED UNDER THE PATENT COOPERATION TREATY (PCT)

(19) World Intellectual Property Organization
International Bureau



(43) International Publication Date
19 December 2002 (19.12.2002)

PCT

(10) International Publication Number
WO 02/100461 A2

- (51) International Patent Classification?: **A61M**
- (21) International Application Number: PCT/US02/19450
- (22) International Filing Date: 12 June 2002 (12.06.2002)
- (25) Filing Language: English
- (26) Publication Language: English
- (30) Priority Data:
60/297,861 12 June 2001 (12.06.2001) US
- (63) Related by continuation (CON) or continuation-in-part (CIP) to earlier application:
US 60/297,861 (CIP)
Filed on 12 June 2001 (12.06.2001)
- (71) Applicant (for all designated States except US): **PELIKAN TECHNOLOGIES, INC.** [US/US]; 1072 East Meadow Circle, Palo Alto, CA 94303 (US).
- (72) Inventors; and
- (75) Inventors/Applicants (for US only): **ALDEN, Donald** [US/US]; 1312 Nelson Way, Sunnyvale, CA 94087 (US). **FREEMAN, Dominique, M.** [GB/US]; 4545 La Honda Road, La Honda, CA 94020 (US). **LUM, Paul** [US/US]; 690 Templebar Way, Los Altos, CA 94022 (US). **DRBAL, Vladimir** [US/US]; Suite 4812, 400 Davey Glen Road, Belmont, CA 94002 (US). **BOECKER, Dirk** [DE/US]; 1652 Casteilleja Avenue, Palo Alto, CA 94306 (US). **VERDONK, Edward, Dennis** [CA/US]; 1914 Jonathan Avenue, San Jose, CA 951256 (US).
- (74) Agents: **SEIDMAN, Stephanie, L.** et al.; Heller Ehrman White & McAuliffe LLP, 4350 La Jolla Village Drive, 7th Floor, San Diego, CA 92122-1246 (US).
- (81) Designated States (*national*): AE, AG, AL, AM, AT, AU, AZ, BA, BB, BG, BR, BY, BZ, CA, CH, CN, CO, CR, CU, CZ, DE, DK, DM, DZ, EC, EE, ES, FI, GB, GD, GE, GH, GM, HR, HU, ID, IL, IN, IS, JP, KE, KG, KP, KR, KZ, LC, LK, LR, LS, LT, LU, LV, MA, MD, MG, MK, MN, MW, MX, MZ, NO, NZ, OM, PH, PL, PT, RO, RU, SD, SE, SG, SI, SK, SL, TJ, TM, TN, TR, TT, TZ, UA, UG, US, UZ, VN, YU, ZA, ZM, ZW.
- (84) Designated States (*regional*): ARIPO patent (GH, GM, KE, LS, MW, MZ, SD, SL, SZ, TZ, UG, ZM, ZW), Eurasian patent (AM, AZ, BY, KG, KZ, MD, RU, TJ, TM), European patent (AT, BE, CH, CY, DE, DK, ES, FI, FR, GB, GR, IE, IT, LU, MC, NL, PT, SE, TR), OAPI patent (BF, BJ, CF, CG, CI, CM, GA, GN, GQ, GW, ML, MR, NE, SN, TD, TG).

Declaration under Rule 4.17:

— as to the applicant's entitlement to claim the priority of the earlier application (Rule 4.17(iii)) for the following designations AE, AG, AL, AM, AT, AU, AZ, BA, BB, BG, BR, BY, BZ, CA, CH, CN, CO, CR, CU, CZ, DE, DK, DM, DZ, EC, EE, ES, FI, GB, GD, GE, GH, GM, HR, HU, ID, IL, IN, IS, JP, KE, KG, KP, KR, KZ, LC, LK, LR, LS, LT, LU, LV, MA, MD, MG, MK, MN, MW, MX, MZ, NO, NZ, OM, PH, PL, PT, RO, RU, SD, SE, SG, SI, SK, SL, TJ, TM, TN, TR, TT, TZ, UA, UG, UZ, VN, YU, ZA, ZM, ZW, ARIPO patent (GH, GM, KE, LS, MW, MZ, SD, SL, SZ, TZ, UG, ZM, ZW), Eurasian patent (AM, AZ, BY, KG, KZ, MD, RU, TJ, TM), European patent (AT, BE, CH, CY, DE, DK, ES, FI, FR, GB, GR, IE, IT, LU, MC, NL, PT, SE, TR), OAPI patent (BF, BJ, CF, CG, CI, CM, GA, GN, GQ, GW, ML, MR, NE, SN, TD, TG)

[Continued on next page]

(54) Title: METHOD AND APPARATUS FOR IMPROVING SUCCESS RATE OF BLOOD YIELD FROM A FINGERSTICK

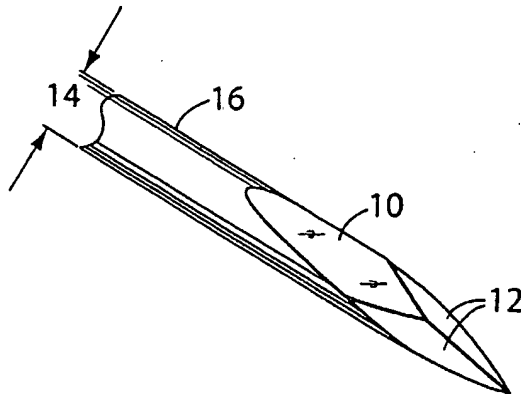

(57) Abstract: A lancet and method for using a lancet to maintain the patency of the wound tract once the lancet has cut into the skin. Blood is allowed to flow up through the wound tract and onto the surface of the skin in some embodiments because the lancet, a helix, or an elastomer coats or braces the wound tract, keeping it open and patent.

WO 02/100461 A2

WO 02/100461 A2



Published:

— without international search report and to be republished upon receipt of that report

For two-letter codes and other abbreviations, refer to the "Guidance Notes on Codes and Abbreviations" appearing at the beginning of each regular issue of the PCT Gazette.

METHOD AND APPARATUS FOR IMPROVING SUCCESS RATE OF BLOOD
YIELD FROM A FINGERSTICK

TECHNICAL FIELD

Lancing devices are well known in the medical health-care products industry for piercing the skin to produce blood for analysis. Biochemical analysis of blood samples is a diagnostic tool for determining clinical information. Many point-of-care tests are performed using capillary whole blood, the most common being monitoring diabetic blood glucose level. Other uses for this method include the analysis of oxygen and coagulation based on Prothrombin time measurement. Typically, a drop of blood for this type of analysis is obtained by making a small incision in the fingertip, creating a small wound which generates a small blood droplet on the surface of the skin.

BACKGROUND ART

Early methods of lancing included piercing or slicing the skin with a needle or razor. Current methods utilize lancing devices that contain a multitude of spring, cam and mass actuators to drive the lancet. These include cantilever springs, diaphragms, coil springs, as well as gravity plumbs used to drive the lancet. Typically, the device is pre-cocked or the user cocks the device. The device is held against the skin and mechanically triggers the ballistic launch of the lancet. The forward movement and depth of skin penetration of the lancet is determined by a mechanical stop and/or dampening, as well as a spring or cam which retract the lancet.

Variations in skin thickness and hydration can yield different results from different users of the lancing device. Current devices rely on adjustable mechanical stops or damping to control the lancet's depth of penetration and compensate for skin thickness and hydration. Such mechanical stops do not regulate the acceleration in order to control the velocity of the lancet as it is protracted and retracted. Conversely, cams offer rough control of lancet velocity in and out of the skin, but do not allow for compensation for skin thickness and hydration. Hence, not all lancing events are successful in generating a blood sample sufficient for the desired analytical test.

Success rate means the probability of producing a blood sample with one lancing action which is sufficient in volume to perform the desired analytical test. The blood droplet produced by the action must reach the surface of the skin to be viable for testing. In some instances, blood will flow from the cut blood vessels but is trapped below the surface of the skin, forming a hematoma. In other instances, a subcutaneous wound is created, but no external blood is obtained. The success rate of obtaining an acceptable blood sample with industry standard lancets available on the market today is 75% to 80%; meaning that up to one in five lancing operations will yield insufficient blood or no blood. For patients required to self test five to six times daily, this inability to obtain a blood droplet every time the finger is lanced translates into needlessly repeating a painful protocol.

DISCLOSURE OF INVENTION

In accordance with some embodiments of the invention, a method for lancing uses a lancet, a helix, or an elastomer to maintain the patency of the wound tract once the lancet has cut into the skin. If penetration takes place, and an appropriate number of blood vessels are cut, blood is allowed to flow up through the wound tract and onto the surface of the skin because the lancet, the helix, or the elastomer coats or braces the wound tract, keeping it open and patent. Coating or bracing is defined generally as keeping the wound open so that the blood from the capillaries can reach the surface of the finger. The term flow control can include any means for bracing the wound tract created by the lancet.

It is to be understood that both the foregoing general description and the following detailed description are exemplary and explanatory only and are not restrictive of the invention, as claimed.

BRIEF DESCRIPTION OF DRAWING

The objects, advantages and features of this invention will be more readily appreciated from the following detailed description, when read in conjunction with the accompanying drawing, in which:

Figure 1 illustrates a typical lancet showing the parameters which affect lancing pain, blood volume, and success rate.

Figure 2 illustrates lancet parameters.

Figure 3 is a graph showing displacement of the lancet over time.

5 Figure 4 is a graph showing velocity of the lancet over time for slowed retraction of the lancet embodiment.

Figure 5 illustrates the lancet before, during and after the incision for a retractable coil embodiment.

Figure 6 illustrates a finger wound tract braced in the elastomer embodiment.

10 BEST MODE FOR CARRYING OUT THE INVENTION

Figure 1 shows a standard industry lancet for glucose testing which has a three-facet geometry. The lancet (16) is produced by taking a rod of diameter (14) and grinding a plane 8 degrees to the plane of the primary axis to create the primary facet (10). The secondary facets (12) are then created by rotating the shaft of the needle 15
15 degrees, and then rolling over 12 degrees to the plane of the primary facet. Other possible geometries require altering the lancet's production parameters such as shaft diameter, angles, and translation distance.

Figure 2 illustrates facet and tip geometry (20) and (22), diameter (24), and depth (26) which are significant factors in reducing pain, blood volume and success rate. It
20 is known that additional cutting by the lancet is achieved by increasing the shear percentage or ratio of the primary to secondary facets, which when combined with reducing the lancet's diameter reduces skin tear and penetration force and gives the perception of less pain. Overall success rate of blood yield, however, also depends on a variety of factors, including the existence of facets, facet geometry, and skin anatomy.

25 Anatomically, the fingertip has a capillary mesh network sufficient to yield 30 to 60 microliters of blood, but the fingertip also has a dense nerve network. The thenar web's nerve network is less dense than the fingertip, but the thenar web also has a less dense capillary network which cannot offer blood volume on the order of the fingertip. The forearm does not produce successful blood samples due to the completely different
30 skin tensile properties. The wound tract seals up following lancet withdrawal,

preventing the blood from reaching the surface, and lancing is usually accompanied by hematoma. Lancing the forearm requires large diameter lancets and active pumping to collect enough blood for testing.

5 Other known mechanisms for increasing the success rate of blood yield rely on creating a vacuum, suctioning the wound, applying an adhesive strip, vibration while cutting, or initiating a second lance if the first is unsuccessful. None of these methods address the interaction of the lancet with the tissue during wound creation.

Reference will now be made in detail to embodiments of the devices and methods having features of the invention. Lancing is defined generally herein as penetrating the skin and cutting blood vessels for the purpose of collecting a blood sample. In some 10 embodiments of the invention, lancet interaction with the skin tissue is controlled while creating the wound so as to yield an appropriate amount of blood every time. Achieving a sampling success rate to near 100% can be an important factor to successfully combining sampling and acquisition of the sample into an integrated sampling module. 15 An example of an integrated sampling module could be an integrated glucose sampling module which incorporates a glucose test strip.

Slowed retraction of a lancet embodiment braces the wound by keeping the tract from closing and keeping the flap created at the skin surface from sealing the opening at the top of the tract. During the slowed retraction, blood is allowed to accumulate and 20 follow the lancet back through the incision. Embodiments of the present invention contemplate numerous devices and methods for providing such blood flow control. To achieve a controlled slowed retraction, a lancet driver is preferably able to retract the lancet at a different velocity than the velocity of the lancet during creation of the incision. Such controlled retraction is achieved by altering spring or cam drivers, or 25 using an electric lancet actuator so that retraction velocity follows a predetermined profile.

Figure 3 shows the displacement versus time profile of a lancet for a controlled lancet retraction for one embodiment. Figure 4 shows the velocity of the lancet versus time profile of the lancet for a controlled retraction. The lancet driving mechanism 30 controls lancet displacement and velocity at several steps in the lancing cycle, including when the lancet cuts the blood vessels to allow blood to pool (30), and as the lancet

retracts, regulating the retraction rate to allow the blood to flood the wound tract while keeping the wound flap from sealing the channel (32) to permit blood to exit the wound. This can be achieved by a mechanical or electric actuator. An electric actuator is described in a copending application (Attorney Docket Number 38187-2551, Inventors: Don Alden, *et al.*, entitled "ELECTRIC LANCET ACTUATOR") submitted on the same day and assigned to the same assignee as the present application. This copending application discloses a mechanism for driving a lancet, to achieve the controlled retraction described in the present invention. Said copending application is incorporated by reference in its entirety herein.

Control during retraction of the lancet involves controlling the velocity of the lancet based on the lancet position. This can be done using a mechanically predetermined path or can be dynamically altered using an electrical position feedback mechanism as described in a copending application (Attorney Docket Number 38187-2558, Inventors: Dominique Freeman, *et al.*, entitled "SELF-OPTIMIZING LANCING DEVICE WITH ADAPTATION MEANS TO TEMPORAL VARIATIONS IN CUTANEOUS PROPERTIES") submitted on the same day and assigned to the same assignee as the present application. This copending application discloses embodiments that that control a lancet to achieve a controlled retraction. Said copending application is incorporated by reference in its entirety herein.

Figure 5 shows the use of an embodiment of the invention which includes a retractable coil. A coiled helix or tube (40) is attached externally to lancet (42) with the freedom to slide such that when the lancet penetrates the skin (50), the helix or tube (40) follows the trajectory of the lancet (16). The helix begins the lancing cycle coiled around the facets and shaft of the lancet (44). As the lancet penetrates the skin, the helix braces the wound tract around the lancet (46). As the lancet retracts, the helix remains to brace open the wound tract, keeping the wound tract from collapsing and keeping the surface skin flap from closing (48). This allows blood (52) to pool and flow up the channel to the surface of the skin. The helix is then retracted as the lancet pulls the helix to the point where the helix is decompressed to the point where the diameter of the helix becomes less than the diameter of the wound tract and becomes dislodged from the skin.

The tube or helix (40) is made of wire or metal of the type commonly used in angioplasty stents such as stainless steel, nickel titanium allow or the like. Alternatively the tube or helix (40) or a ring can be made of a biodegradable material, which braces the wound tract by becoming lodged in the skin. Biodegradation is completed within
5 seconds or minutes of insertion, allowing adequate time for blood to pool and flow up the wound tract. Biodegradation is activated by heat or pH from the skin.

Other methods of keeping the wound open include coating the lancet with a powder, which coats the wound tract and keeps it open when the lancet is withdrawn. The powder is a coarse bed of microspheres or capsules which hold the channel open
10 while allowing blood to flow through the porous interstices.

In another embodiment the wound is held open using a two part needle, the outer part in the shape of a "U" and the inner part filling the "U." After creating the wound the inner needle is withdrawn leaving an open channel, rather like the plugs that are commonly used for withdrawing sap from maple trees.

Figure 6 shows a further embodiment of this invention utilizing an elastomer to coat the wound. This method uses an elastomer (54), such as silicon rubber, to coat or brace the wound tract (56) by covering and stretching the surface of the finger (58). The elastomer (54) is applied to the finger (58) prior to lancing. After a short delay , the lancet (not shown) then penetrates the elastomer (54) and the skin on the surface of
15 the finger (58) as is seen in (60). Blood is allowed to pool and rise to the surface while the elastomer (54) braces the wound tract (56) as is seen in (62) and (64). An added benefit of using the elastomer (54) to cover the skin is seamless sampling for blood gas analysis as described in a copending application (Attorney Docket Number 38187-2553, Inventors: Vladimir Drbal, *et al.*, entitled "BLOOD SAMPLING DEVICE WITH
20 DIAPHRAGM ACTUATED LANCET") submitted on the same day and assigned to the same assignee as the present application. This copending application discloses how to acquire a blood sample that is not contaminated by substantial amounts of ambient air, and could therefore provide a viable sample of gas analysis. Said copending application is incorporated by reference in its entirety herein.

30 Other embodiments of the invention will be apparent to those skilled in the art from consideration of the specification and practice of the invention disclosed herein.

It is intended that the specification and examples be considered as exemplary only, with a true scope and spirit of the invention being indicated by the following claims.

CLAIMS

1. A method for sampling blood comprising the steps of:
lancing a piece of skin to create a wound tract; and
bracing the wound tract.
- 5 2. A method of sampling blood according to claim 1 wherein:
said bracing comprises controlling the retraction velocity of a lancet.
3. A method for sampling blood according to claim 2 wherein:
said controlling comprises of monitoring the displacement of the lancet.
- 10 4. A method of sampling blood according to claim 1 wherein:
said bracing comprises inserting a tube in the wound tract.
5. A method of sampling blood according to claim 1 wherein:
15 said bracing comprises stretching the piece of skin before and after said
lancing.
6. A method of sampling blood comprising the steps of:
puncturing a piece of skin to create a wound tract; and
20 bracing said wound tract with a biodegradable structure to permit a
controlled sample of blood to exit said wound tract.
7. An apparatus for sampling blood comprising:
a lancet; and
25 a flow control for bracing a wound tract created by the lancet.
8. An apparatus for sampling blood according to claim 7 wherein:
said flow control comprises a controlled retraction of the lancet from the
wound tract.

- 5
9. An apparatus for sampling blood according to claim 7 wherein:
said flow control comprises a tube attached to said lancet for bracing the
wound tract during lancet retraction.
- 10
10. An apparatus for sampling blood according to claim 7 wherein:
said flow control comprises a means for stretching the wound tract open.
11. An apparatus for sampling blood according to claim 7 wherein:
said flow control comprises a powder coated on said lancet for bracing
the wound tract after lancet retraction.
- 15
12. An apparatus for sampling blood according to claim 7 wherein:
said lancet comprises a U-shaped sheath; and
said flow control comprises retracting the U-shaped sheath after the
remainder of lancet is retracted.

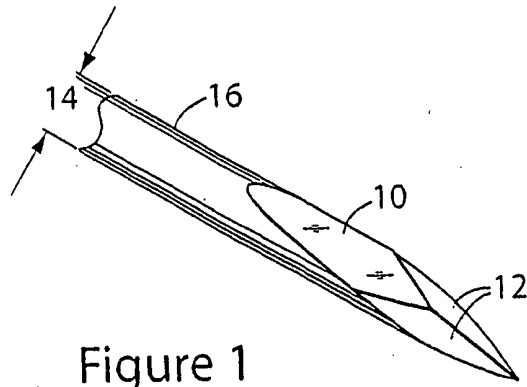

Figure 1

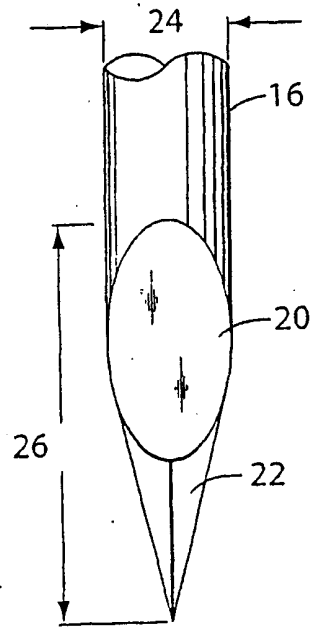

Figure 2

Figure 3

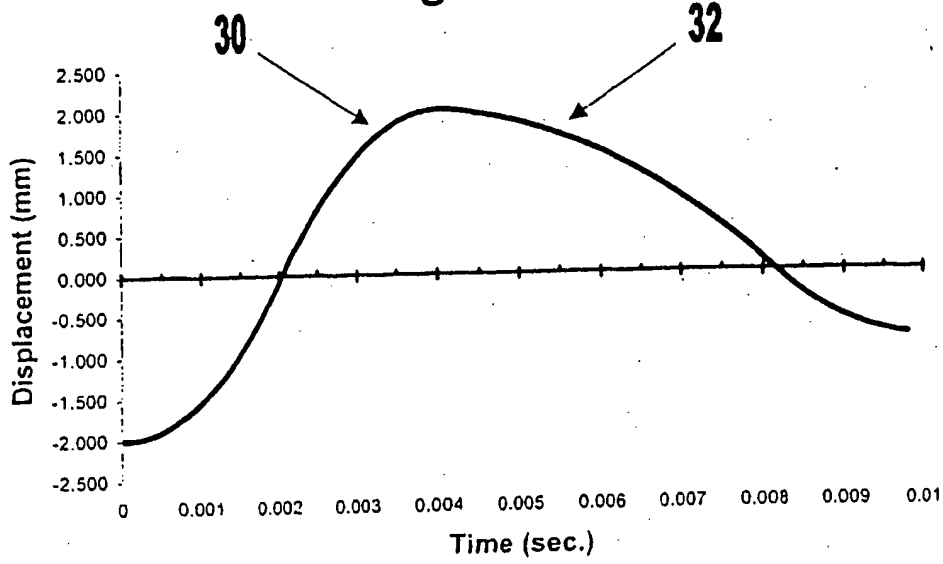
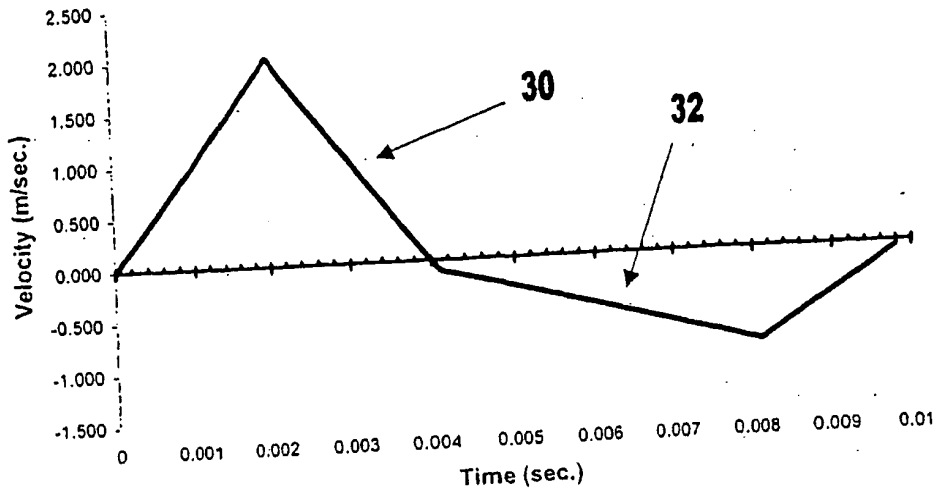

Figure 4



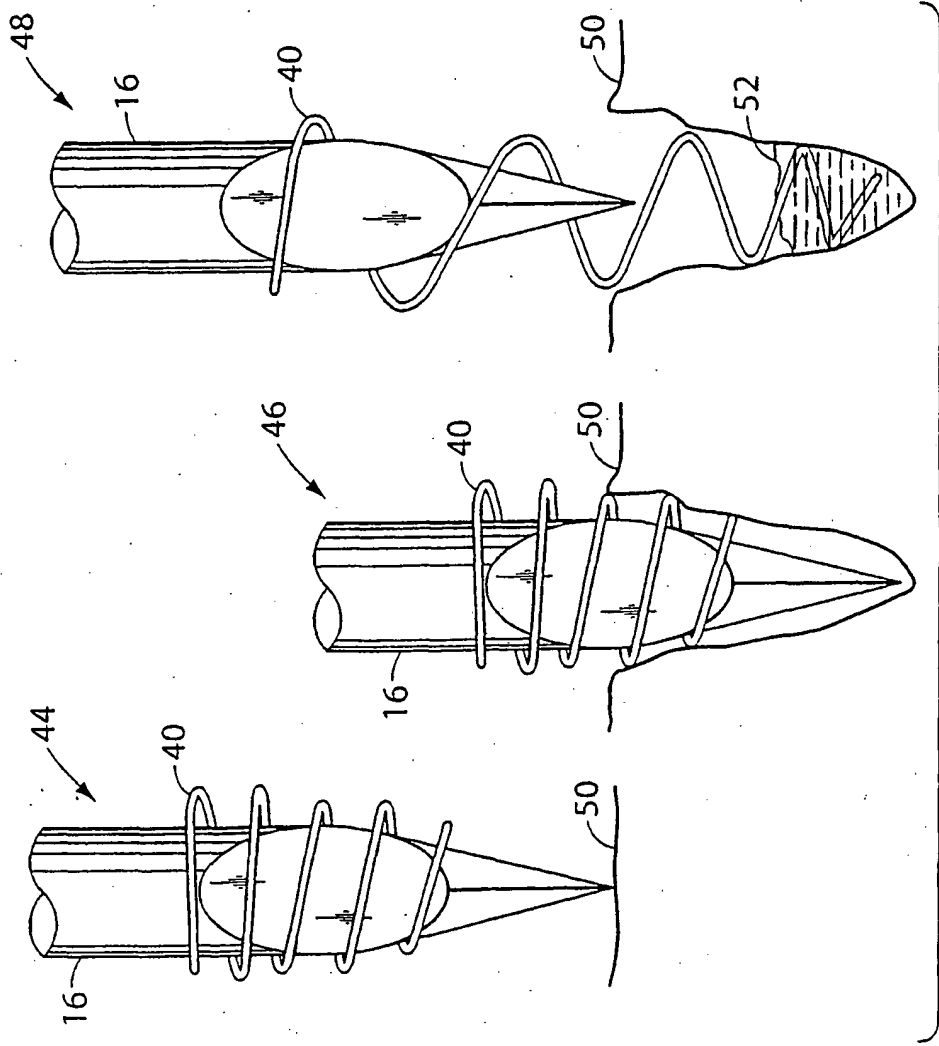

Figure 5

5 / 5

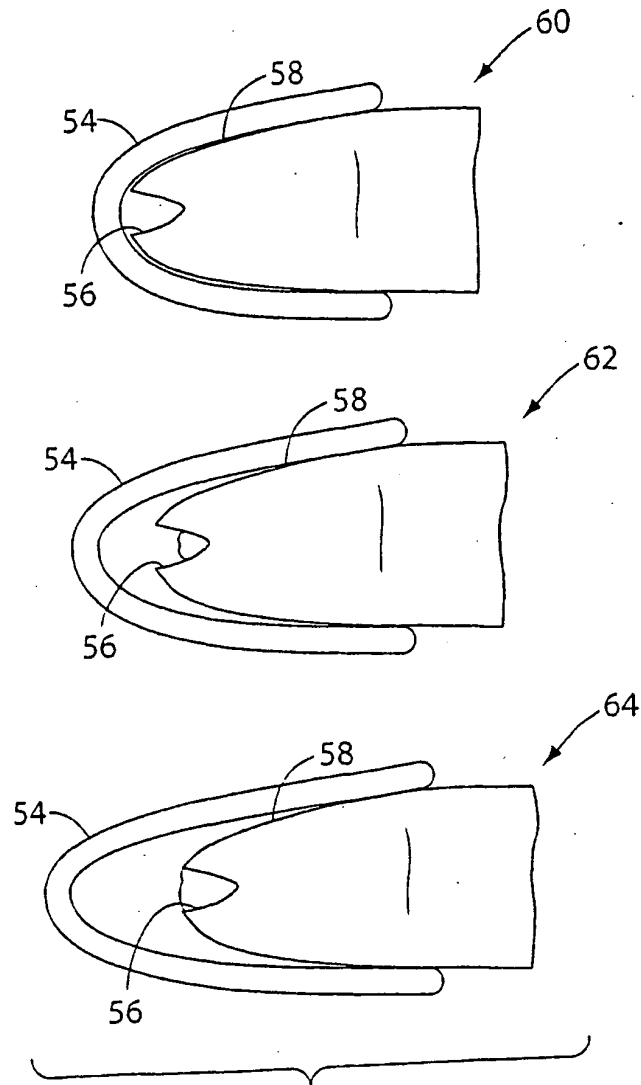

Figure 6